



**DESIGN TECHNOLOGY  
STANDARD LEVEL  
PAPER 3**

Friday 12 November 2010 (morning)

1 hour

Candidate session number

0	0							
---	---	--	--	--	--	--	--	--

**INSTRUCTIONS TO CANDIDATES**

- Write your session number in the boxes above.
- Do not open this examination paper until instructed to do so.
- Answer all of the questions from one of the Options in the spaces provided. You may continue your answers on answer sheets. Write your session number on each answer sheet, and attach them to this examination paper and your cover sheet using the tag provided.
- At the end of the examination, indicate the letter of the Option answered in the candidate box on your cover sheet and indicate the number of answer sheets used in the appropriate box on your cover sheet.



**Option A — Food science and technology**

**A1.** Figure A1 shows the steps in the making of pizza dough using wheat flour, yeast, water, salt and olive oil.

**Figure A1: Steps in making a pizza dough**



1. Mix flour, yeast, water, salt and olive oil for pizza dough.



2. Gather the dough into a large ball on a floured board.



3. Knead the dough by pushing with heel of one hand.



4. Now reverse the process, kneading with the other hand.



5. Place the dough in a bowl in a warm spot, and cover it.



6. When the dough has doubled in bulk take it out.



7. Divide the dough into quarters to make pies.



8. Press down with palm on a piece, flattening it.



9. Turn dough in your hands and stretch it out.



10. Hold the dough and let its weight stretch it.



11. Use a rolling pin to work it into a circle.



12. Pour on tomato sauce, sprinkle with grated cheese. Dribble olive oil over cheese, and bake.

[Source: "The Cooking of Italy" by Waverly Root. Time Life "Foods of the World", Time Life Books, NY, 1968. Photographs by Michael Field. Page 174.]

*(This question continues on the following page)*



(Question A1 continued)

- (a) State the name of the process which causes the dough to double in volume as shown in step 6. [1]

.....

.....

- (b) Outline **one** reason for adding yeast to the pizza dough as shown in step 1. [2]

.....

.....

.....

- (c) Explain why the recipe for the pizza dough would have to be modified so that it would be suitable as part of a gluten-free diet. [3]

.....

.....

.....

.....

- A2.** (a) Define *water activity*. [1]

.....

.....

- (b) List **two** methods of food preservation which reduce the water activity of foods. [2]

.....

.....

.....



A3. A man has a height of 1.9 metres, a weight of 125 kg and a waist circumference of 117 cm. (see **Figure A2**). Having a waist circumference greater than 102 cm for men has been shown to be a more sensitive indication for increased risk of disease associated with being overweight or obese than body mass index (BMI) ( $\text{kg m}^{-2}$ ) (see **Table A1**).

**Table A1: Disease risk, BMI and waist circumference**

**Figure A2: Man with increased waist circumference**

Classification	BMI ( $\text{kg m}^{-2}$ )	Waist circumference less than 102 cm	Waist circumference more than 102 cm
Underweight	< 18.5	—	—
Normal	18.5–24.9	—	—
Overweight	25.0–29.9	Increased	High
Obesity	30.0–34.9	High	Very high
—	35.0–39.9	Very high	Very high
Extreme Obesity	40.0 +	Extremely high	Extremely high

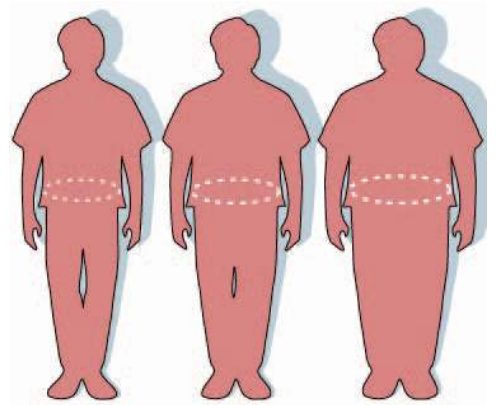

[Source: Report of the Dietary Guidelines Advisory Committee on the Dietary Guidelines for Americans, 2000. Infographic: FDA/Renée Gordon.]

(a) Calculate the BMI for the man.

[2]

.....

.....

.....

(b) Outline **one** reason why governments should raise public awareness of health issues relating to obesity.

[2]

.....

.....

.....



**A4.** Describe the role of emulsifiers in stabilizing food emulsions. [2]

.....  
.....  
.....

**A5.** Discuss the influence of market pull and technology push on the development of new food products. [6]

Market pull:

.....  
.....  
.....  
.....

Technology push:

.....  
.....  
.....  
.....



A6. Discuss **three** issues relating to the effectiveness of legislation governing food labelling as a means of altering diets.

[9]

.....

.....

.....

.....

.....

.....

.....

.....

.....

.....

.....

.....

.....

.....

.....

.....

.....

.....

.....

.....

.....

.....

.....

.....



**Option B — Electronic product design**

**B1.** The circuit shown in **Figure B1** is part of a combination lock for an entry control system to a smart home. Logic 1 at Q opens the lock mechanism. There are four push switches labelled A, B, C and D on a control pad. Pressing switch A provides a logic 1 at A. Switches B, C and D operate in the same way as switch A.

**Figure B1: Part of a combination lock for an entry control system to a smart home**

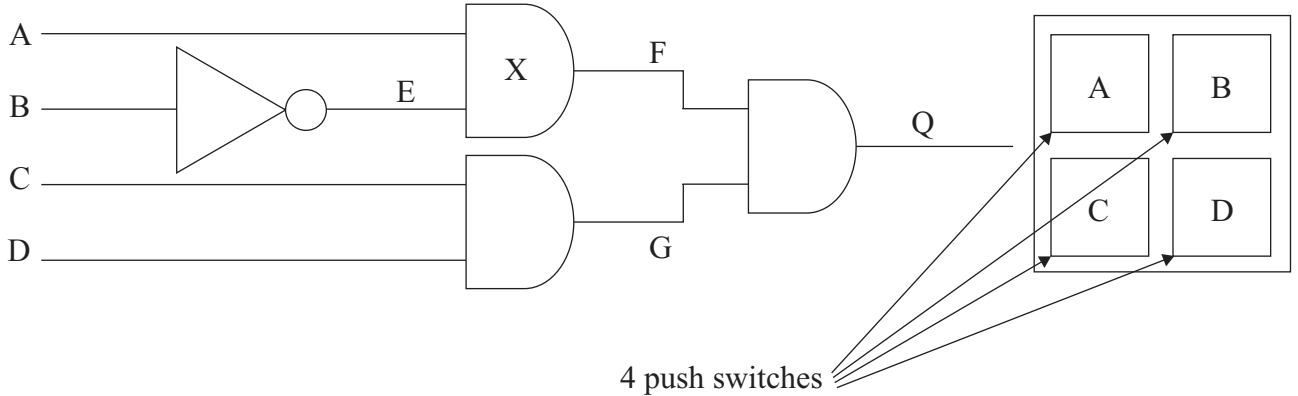

(a) State the name of the logic gate labelled X. [1]

.....  
 .....

(b) Complete the truth table shown below. [2]

B	A	E	F
0	0		
0	1		
1	0		
1	1		

(c) Explain which combination of switches needs to be pushed to open the lock mechanism. [3]

.....  
 .....  
 .....  
 .....



**B2.** (a) Define *programmable interface controller* (PIC). [1]

.....  
.....

(b) Identify **one** way in which a PIC can extend the product life of a hearing aid. [2]

.....  
.....  
.....

**B3.** **Figure B2** shows a circuit used as part of a public address system. To achieve the appropriate level of amplification  $V_{out}$  must be ten times  $V_{in}$ .

**Figure B2: Circuit used as part of a public address system**

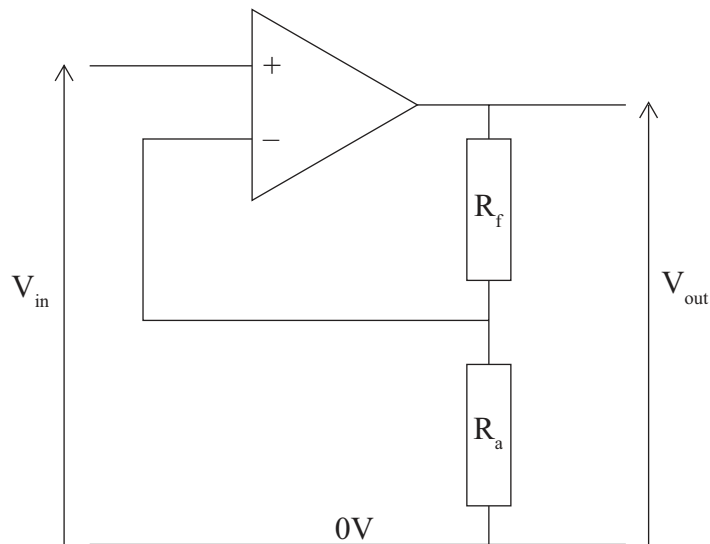

(a) Identify the ratio of  $R_f$  to  $R_a$  to achieve an amplification of ten times. [2]

.....  
.....  
.....

(b) Outline **one** reason why  $R_a$  and  $R_f$  should not be very low (*e.g.* less than 1 k $\Omega$ ) or very high (*e.g.* more than 10 k $\Omega$ ). [2]

.....  
.....  
.....





**B4.** Identify **one** advantage of a single mode fibre optic cable over a multi-mode fibre optic cable. [2]

.....  
.....  
.....

**B5.** The circuit shown in **Figure B3** is part of an alarm system for a smart home. The user is given approximately 20 seconds to enter the correct code on a keypad (not shown in the diagram) before the alarm sounds. This circuit is designed to switch from logic 1 to logic 0 for a period of approximately 20 seconds when the switch is moved from position A to position B.

**Figure B3: Circuit for part of an alarm system for a smart home**

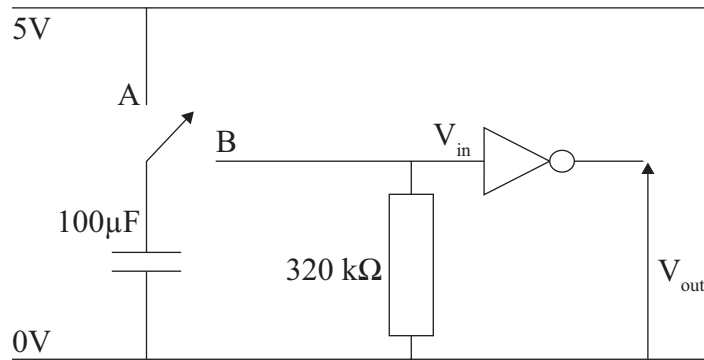

(a) Explain why the component values given for the resistor and capacitor are suitable for producing a time of approximately 20 seconds. [3]

.....  
.....  
.....  
.....

(b) Explain the effect of connecting a 200µF capacitor in parallel with the 100µF capacitor on the duration of the logic 0 output. [3]

.....  
.....  
.....  
.....



**B6.** Explain the limitations of an open loop control system and how positive and negative feedback are used in a closed loop system to overcome these limitations. [9]

.....

.....

.....

.....

.....

.....

.....

.....

.....

.....

.....

.....

.....

.....

.....

.....

.....

.....

.....

.....

.....

.....

.....



**Option C — CAD/CAM**

**C1.** **Figure C1** shows a CNC router. **Figure C2** shows a twin flute straight cutting tool with a 1/4 inch shank, 3/16 inch diameter and a 1/2 inch length. **Figure C3** shows the Ben Wilson Chairfix design. The chair is routed out of birch-faced plywood or MDF. The chair is easily assembled in minutes by the end user. No glue, screws or other fixings are needed.

**Figure C1: A CNC router    Figure C2: Twin flute straight cutting tool    Figure C3: Ben Wilson’s Chairfix design**



[Used with the permission of Trend Cutting Tools Ltd.]

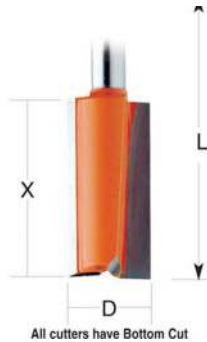

All cutters have Bottom Cut

[Image used with the permission of CMT Orange Tools (www.cmtutensili.com).]



[Chairfix by Ben Wilson (www.benwilsondesign.co.uk).]

(a) State **one** benefit for the manufacturer of using a CNC router for the manufacture of the Ben Wilson Chairfix design shown in Figure C3. [1]

.....  
.....

(b) Describe how the straight cutting tool would be used to make the parts in Figure C3. [2]

.....  
.....  
.....

(c) Explain how a CNC machine aids manufacture. [3]

.....  
.....  
.....  
.....



C2. (a) Define *feed speed*. [1]

.....  
.....

(b) Outline **one** reason why feed speed is changed to suit material and tooling properties. [2]

.....  
.....  
.....



C3. **Figure C4** shows a CAD image of a chair. **Figure C5** shows a CAD image of a wheel for a child’s toy. Both are produced from 2–D sketches.

**Figure C4: CAD image of a chair**

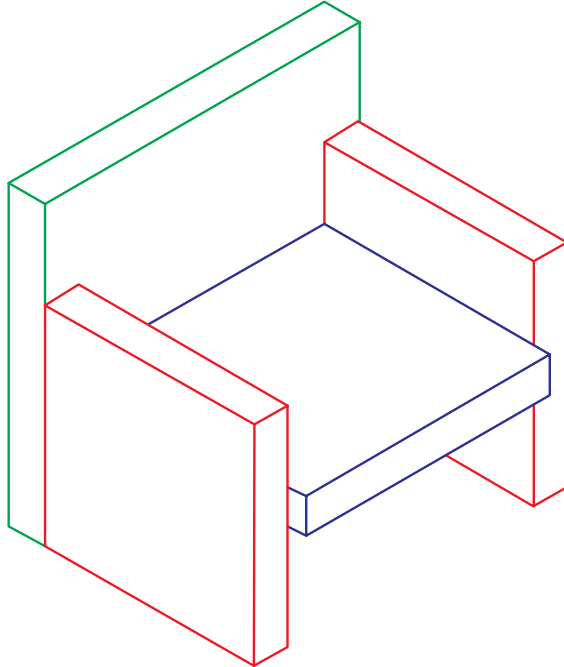

Redrawn from [http://www.we-r-here.com/cad/tutorials/level\\_3/3-5.htm](http://www.we-r-here.com/cad/tutorials/level_3/3-5.htm). Used with permission.

**Figure C5: CAD image of a wheel for a child’s toy**

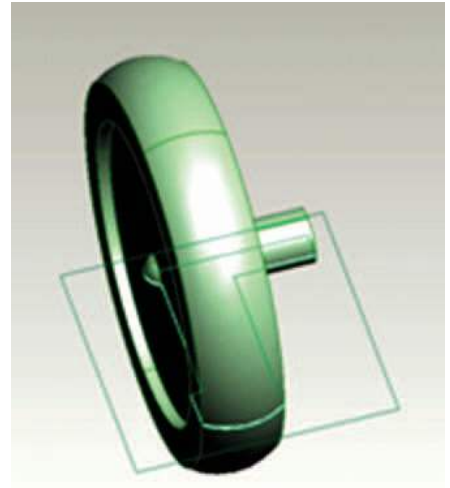

(a) Identify the process which would be used to produce a 3–D image of the back of the chair shown in Figure C4 from a 2–D sketch. [2]

.....  
.....  
.....

(b) Identify the process which would be used to produce the image of the wheel shown in Figure C5 from a 2–D sketch. [2]

.....  
.....  
.....



**C4.** List **two** input devices which can be used with CAD. [2]

.....  
.....  
.....

**C5.** Discuss **two** ways in which CAD has affected consumer choice when considering a kitchen design. [6]

.....  
.....  
.....  
.....  
.....  
.....  
.....  
.....  
.....  
.....  
.....



C6. Discuss **three** benefits of using CAD with rapid prototyping for the designers of electronic products. [9]

.....  
.....  
.....  
.....  
.....  
.....  
.....  
.....  
.....  
.....  
.....  
.....  
.....  
.....  
.....  
.....  
.....  
.....  
.....  
.....  
.....  
.....



**Option D — Textiles**

**D1.** Care labels for clothing and textile products are produced to international standards and adopted in individual countries. **Figure D1**, for example, shows the cover of a guide to the care labelling standards produced by the Australian Competition and Consumer Commission. Care instruction must be permanently attached to products and accessible at the point of sale.

**Figure D1: Consumer guide to fabric care symbols**



[© Commonwealth of Australia. Used with the permission of the Australian Competition and Consumer Commission.]

(a) State **one** reason why care labelling for textile products should be mandatory. [1]

.....

.....

*(This question continues on the following page)*



*(Question D1 continued)*

(b) Outline **one** reason why the care instructions should be accessible at the point of sale. [2]

.....  
.....  
.....

(c) Explain why there is a need for international standards for care labels. [3]

.....  
.....  
.....  
.....

**D2.** (a) State **one** property of silk. [1]

.....  
.....

(b) Outline **one** reason why silk production promoted international trade. [2]

.....  
.....  
.....



**D3.** VELCRO<sup>®</sup> consists of two layers – one is covered with tiny hooks, the other with tiny loops. When the two layers are pressed together, the hooks catch in the loops and hold the pieces together (see **Figure D2**). VELCRO<sup>®</sup> was invented by George de Mestral, a Swiss engineer. The idea came to him after he returned home one day with his clothes covered in the seeds (burrs) of the burdock plant (see **Figure D3**). VELCRO<sup>®</sup> is widely used for the fasteners of trainers and other sports clothing (see **Figure D4**).

**Figure D2: Magnified images of VELCRO<sup>®</sup> showing the tiny hooks and loops**



**Figure D3: Tiny hooks on the seeds of the burdock plant**



[Source: [http://en.wikipedia.org/wiki/File:Bur\\_Macro\\_BlackBg.jpg](http://en.wikipedia.org/wiki/File:Bur_Macro_BlackBg.jpg). Image by Zephyris.]

**Figure D4: Child's trainer with VELCRO<sup>®</sup> fastening**



[Source: <http://commons.wikimedia.org/wiki/File:Kinderschoenen.jpg>. Image by Dmitri Neyt (DimiTalen, DimiCalifornia).] [2]

Source: [http://en.wikipedia.org/wiki/File:Velcro\\_hooks.jpg](http://en.wikipedia.org/wiki/File:Velcro_hooks.jpg) and [http://en.wikipedia.org/wiki/File:Velcro\\_loops.jpg](http://en.wikipedia.org/wiki/File:Velcro_loops.jpg). Images by Olivepixel.

(a) Identify **one** way in which VELCRO<sup>®</sup> is an example of biomimetics.

.....  
 .....  
 .....

(b) Outline **one** advantage of using VELCRO<sup>®</sup> for the fastener of the child's trainer shown in Figure D4.

.....  
 .....  
 .....

[2]



**D4.** Describe how a packaging material can affect the promotion of textile products. [2]

.....  
.....  
.....

**D5.** Discuss **two** ways in which the use of CAM in the textile industry has helped to minimise waste. [6]

.....  
.....  
.....  
.....  
.....  
.....  
.....  
.....  
.....  
.....  
.....



**D6.** Explain **three** factors that contribute to expansion of the textile industry due to automation. [9]

.....

.....

.....

.....

.....

.....

.....

.....

.....

.....

.....

.....

.....

.....

.....

.....

.....

.....

.....

.....

.....



**Option E — Human factors design**

**E1.** The Apple iPod has been a global success (see **Figure E1**). It has a touch wheel which rotates to scroll through menu items. The central button is used to select a menu item. The buttons on the touch wheel perform basic functions: menu, play/pause, next track, and previous track.

**Figure E1: The Apple iPod**



Source: iPod. Used with permission.

(a) State **one** characteristic of a product which becomes a global success. [1]

.....  
.....

(b) Outline **one** way in which the user interface of the iPod has contributed to its success. [2]

.....  
.....  
.....

(c) Explain why participatory design involving users helps designers to develop good user interfaces. [3]

.....  
.....  
.....  
.....



E2. (a) Define *population stereotype*. [1]

.....  
.....

(b) Describe the relevance of population stereotypes in the design of controls for products. [2]

.....  
.....  
.....

E3. Figure E2 shows two doors equipped with different door furniture although both need to be pushed to open.

Figure E2: Two doors and door furniture

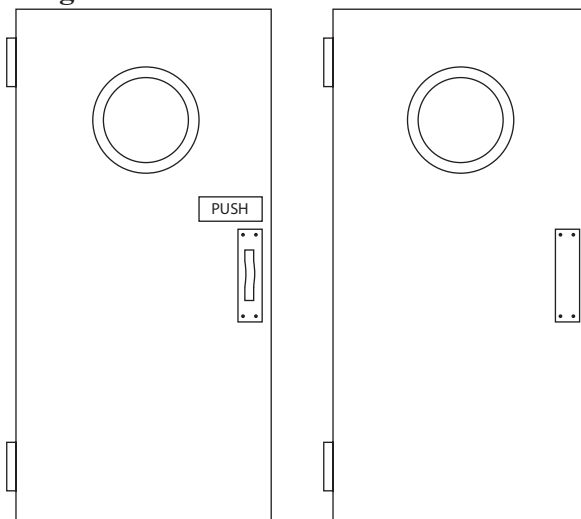

(a) Outline **one** reason why affordance is an important consideration in human factors design. [2]

.....  
.....  
.....

(b) Identify **one** reason why the use of the push plate on the right-hand door in Figure E2 is a better design for a door that needs to be pushed than the handle and sign used on the left-hand door. [2]

.....  
.....  
.....



**E4.** List **two** pieces of anthropometric data which would be used in the design of a mobile phone. [2]

.....  
.....  
.....

**E5.** Discuss **two** ways in which human factor specialists determine adequate product safety. [6]

.....  
.....  
.....  
.....  
.....  
.....  
.....  
.....  
.....  
.....  
.....



**E6.** Explain **three** advantages of using paper prototyping in the design process.

*[9]*

.....  
.....  
.....  
.....  
.....  
.....  
.....  
.....  
.....  
.....  
.....  
.....  
.....  
.....  
.....  
.....  
.....  
.....  
.....  
.....  
.....  
.....  
.....  
.....  
.....  
.....

